

# TIPTrace.ai

## Next-Gen TIP Tracing for Dialed-in Flux Monitoring Calibration

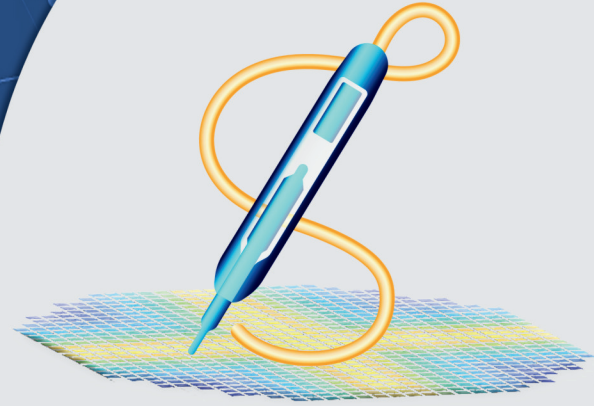

## Trace with Precision - Calibrate with Confidence

TIPTrace.ai enables more accurate TIP traces and therefore more accurate LPRM calibration.

Benefits:

- ✓ Accurate LPRM readings eliminate unnecessary generation losses
- ✓ Avoid safety issues resulting from underestimating thermal limits margins

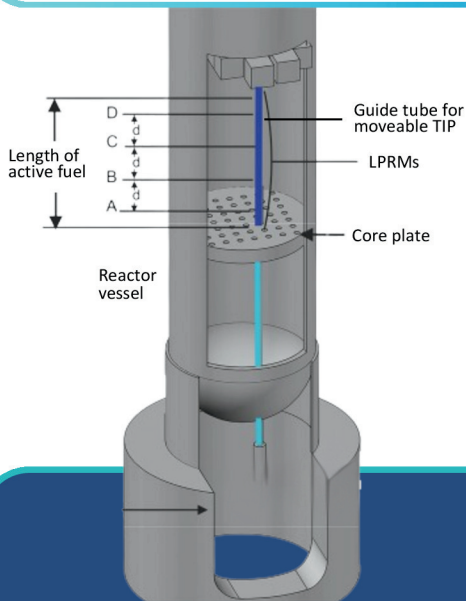

### Challenge:

Raw probe traces are rarely aligned to the reactor core.

### Cause:

The auto TIP alignment feature in most fuel vendors' software occasionally incorrectly shifts the local flux profile by more than a full node.

### Resulting in:

- ✗ Incorrect LPRM calibrations
- ✗ Higher perceived thermal limits (e.g. MFLPD) due to inadequate margin(s)
- ✗ **A power derate (!) if a limit is reached**

### Problem Solved: a More Accurate Algorithm

A custom filtering kernel with peaks separated by the nominal distance between the spacers in the fuel.

The filtering kernel shift function corresponds to the shift value that best aligns with the spacers given the nominal separation values.

## Benefits

- + **Cost Savings:** Avoid unnecessary downtime and generation losses
- + **Enhanced Safety:** Ensure accurate flux monitor calibration and maintain safe thermal limits
- + **Improved Efficiency:** Early detection of fuel bundle spacing defects
- + **Proactive Management:** Identify and address potential issues before they escalate

## Key Features

1. Detection of auto alignment errors
2. New methodology for high fidelity TIP trace adaptation
3. Detect other spurious TIP data and validate LPRM calibrations
4. Provide power distribution curves with unparalleled granularity to the core monitoring system

